

# SANYO

**INSTRUCTION  
MANUAL**

**MEMO-SCRIBER  
Dictating/Transcribing  
System**

**TRC-8800**

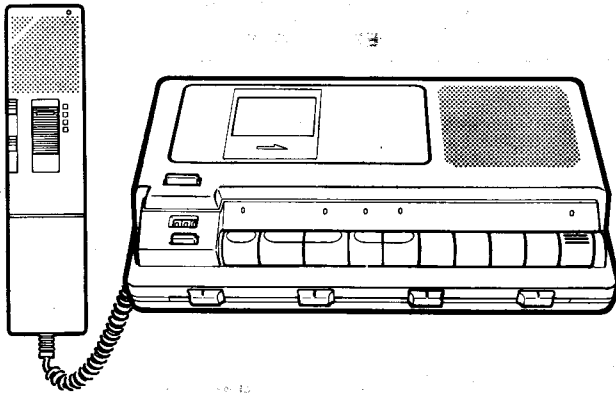

This instruction manual is written in English and Spanish.  
Este manual de instrucciones está escrito en español y inglés.

**SANYO DICTATING/TRANSCRIBING SYSTEM  
MODEL TRC-8800 LIMITED WARRANTY**

**OBLIGATIONS**

In order to obtain warranty service, the product must be delivered to and picked up from an Authorized Sanyo Factory Service Center at the user's expense, unless specifically stated otherwise in this warranty. The names and addresses of Authorized Sanyo Service Centers may be obtained by calling the toll free number listed below.

For product operation, authorized service center referral, service assistance or problem resolution, call  <p align="center"><b>CUSTOMER INFORMATION 1-800-421-5013</b> Weekdays 8:00 AM - 5:00 PM Pacific Time</p>
For accessories and/or parts not available from an authorized dealer, call  <p align="center"><b>PARTS ORDER INFORMATION 1-800-726-9862</b> Weekdays 8:00 AM - 5:00 PM Pacific Time</p>

**THIS WARRANTY IS VALID ONLY ON SANYO PRODUCTS PURCHASED AND USED IN THE UNITED STATES OF AMERICA, EXCLUDING ALL U.S. TERRITORIES AND PROTECTORATES. THIS WARRANTY APPLIES ONLY TO THE ORIGINAL RETAIL USER, AND DOES NOT APPLY TO PRODUCTS USED FOR ANY INDUSTRIAL, PROFESSIONAL OR COMMERCIAL PURPOSE. THE ORIGINAL DATED BILL OF SALE OR SALES SLIP MUST BE SUBMITTED TO THE AUTHORIZED SANYO SERVICE CENTER AT THE TIME WARRANTY SERVICE IS REQUESTED.**

Subject to the OBLIGATIONS above and EXCLUSIONS below, SANYO FISHER COMPANY (SFC) warrants this SANYO product against defects in materials and workmanship for the periods of LABOR and PARTS specified below. SFC will repair or replace (at its option) the product and any of its parts which fail to conform to this warranty. The warranty period commences on the date the product was first purchased at retail.

<b>LABOR</b>	<b>PARTS</b>
<b>90 DAYS</b>	<b>1 YEAR</b>

**EXCLUSIONS**

This warranty does not cover (A) the adjustment of customer-operated controls as explained in the appropriate model's instruction manual, or (B) the repair of any product whose serial number has been altered, defaced or removed.

This warranty shall not apply to the cabinet or cosmetic parts, knobs or routine maintenance.

This warranty does not apply to uncrating, setup, installation, removal of the product for repair or reinstallation of the product after repair.

This warranty does not apply to repairs or replacements necessitated by any cause beyond the control of SFC including, but not limited to, any malfunction, defect or failure caused by or resulting from unauthorized service or parts, improper maintenance, operation contrary to furnished instructions, shipping or transit accidents, modification or repair by the user, abuse, misuse, neglect, accident, incorrect power line voltage, fire, flood or other Acts of God, or normal wear and tear. The foregoing is in lieu of all other expressed warranties and SFC does not assume or authorize any party to assume for it any other obligation or liability.

THE DURATION OF ANY WARRANTIES WHICH MAY BE IMPLIED BY LAW (INCLUDING THE WARRANTIES OF MERCHANTABILITY AND FITNESS) IS LIMITED TO THE TERM OF THIS WARRANTY. IN NO EVENT SHALL SFC BE LIABLE FOR SPECIAL, INCIDENTAL OR CONSEQUENTIAL DAMAGES ARISING FROM OWNERSHIP OR USE OF THIS PRODUCT, OR FOR ANY DELAY IN THE PERFORMANCE OF ITS OBLIGATIONS UNDER THIS WARRANTY DUE TO CAUSES BEYOND ITS CONTROL.

SOME STATES DO NOT ALLOW LIMITATIONS ON HOW LONG AN IMPLIED WARRANTY LASTS AND/OR DO NOT ALLOW THE EXCLUSION OR LIMITATION OF CONSEQUENTIAL DAMAGES, SO THE ABOVE LIMITATIONS AND EXCLUSIONS MAY NOT APPLY TO YOU.

THIS WARRANTY GIVES YOU SPECIFIC LEGAL RIGHTS. YOU MAY HAVE OTHER RIGHTS, WHICH VARY FROM STATE TO STATE.

S/A R11 (M)

For your protection in the event of theft or loss of this product, please fill in the information below for your own personal records.

Model No. _____	Serial No. _____
Date of Purchase _____	(Located on back or bottom side of unit)
Where Purchased _____	Purchase Price _____

**WARNING: TO PREVENT FIRE OR SHOCK HAZARD, DO NOT EXPOSE THIS APPLIANCE TO RAIN OR MOISTURE.**

**CONTROLS**

- |                                                                                                                                                                                                                                                                                                                                                                                                                                       |                                                                                                                                                                                                                                                                                                                                                                                                                                    |
|---------------------------------------------------------------------------------------------------------------------------------------------------------------------------------------------------------------------------------------------------------------------------------------------------------------------------------------------------------------------------------------------------------------------------------------|------------------------------------------------------------------------------------------------------------------------------------------------------------------------------------------------------------------------------------------------------------------------------------------------------------------------------------------------------------------------------------------------------------------------------------|
| <ol style="list-style-type: none"> <li>1. Cassette compartment lid</li> <li>2. Eject lever (EJECT)</li> <li>3. Tape counter and reset button (COUNTER/RESET)</li> <li>4. Backspace control (BACKSPACE)</li> <li>5. Erase button and indicator (ERASE)</li> <li>6. Stop button (STOP)</li> <li>7. Volume control (VOLUME)</li> <li>8. Play button and indicator (PLAY)</li> <li>9. Fast forward button and indicator (FFWD)</li> </ol> | <ol style="list-style-type: none"> <li>10. Rewind button and indicator (REW)</li> <li>11. Tone control (TONE)</li> <li>12. Telephone record button (TEL REC)</li> <li>13. Dictation/Conference button (DICT/CONF)</li> <li>14. Microphone/Speaker button (MIC/SPKR)</li> <li>15. Search button (SEARCH)</li> <li>16. Speed control (SPEED CONTROL)</li> <li>17. Power button and indicator (POWER)</li> <li>18. Speaker</li> </ol> |
|---------------------------------------------------------------------------------------------------------------------------------------------------------------------------------------------------------------------------------------------------------------------------------------------------------------------------------------------------------------------------------------------------------------------------------------|------------------------------------------------------------------------------------------------------------------------------------------------------------------------------------------------------------------------------------------------------------------------------------------------------------------------------------------------------------------------------------------------------------------------------------|

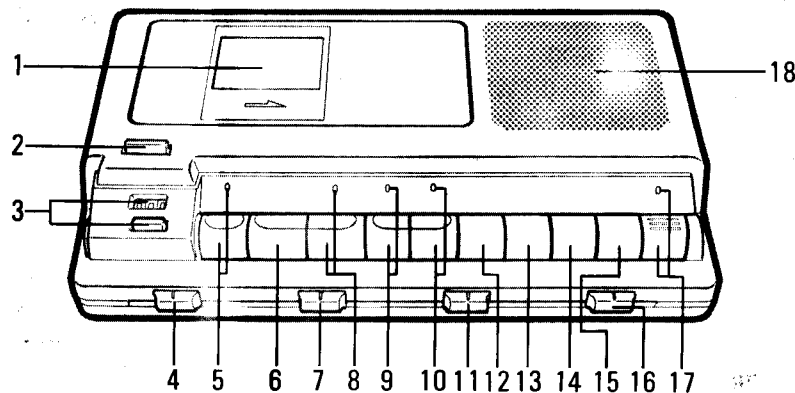

- 19. External DC 9V jack (EXT DC 9V)
- 20. Telephone record jack (TEL REC)

- 21. Remote control jack (REMOTE)
- 22. Earphone jack (EARPHONE)
- 23. Cradle bracket -both sides-
- 24. Hand control cradle

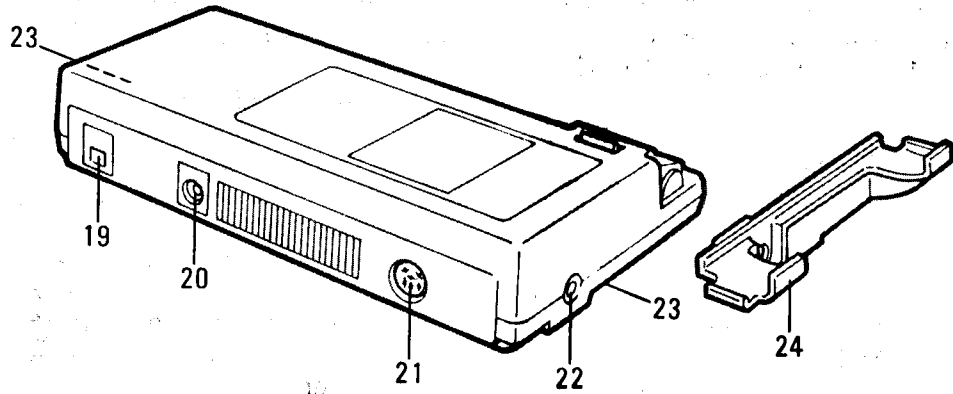

**Hand control**

- 25. Microphone
- 26. Index button (INDEX)
- 27. Fast forward button (FFWD)
- 28. Hand control switch
- 29. Speaker
- 30. Dictation indicator (DICT)

**Foot control**

- 31. Back switch (BACK)
- 32. Play switch (PLAY)
- 33. Fast forward switch (FFWD)

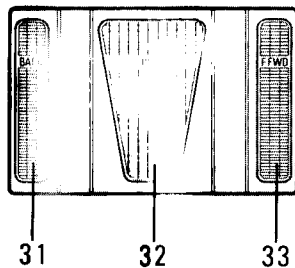
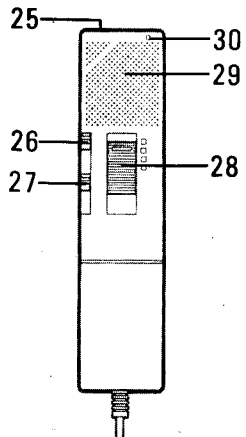

**PREPARATIONS**

**Connections**

**For dictation/conference recording**

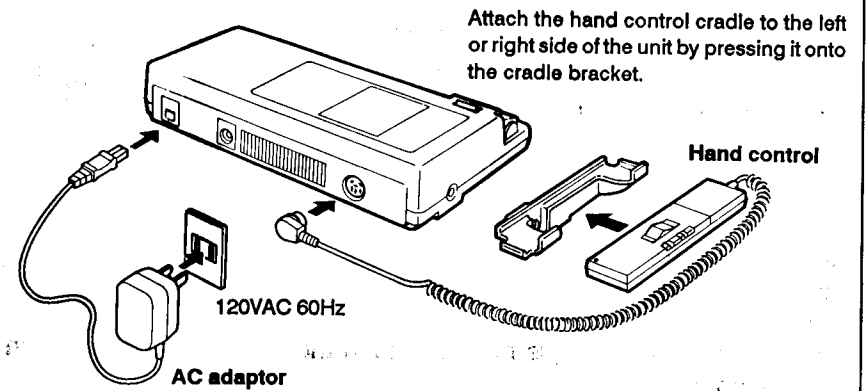

**For transcription**

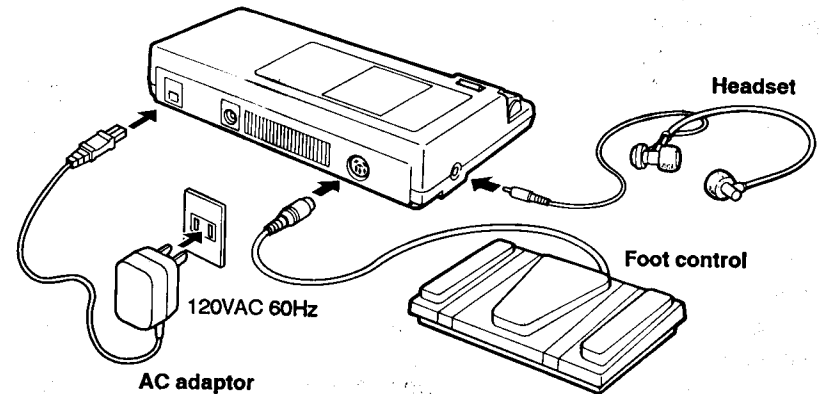

**For telephone recording**

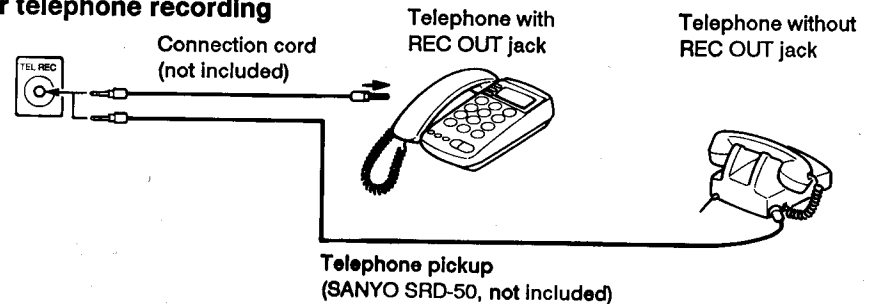

### Loading a cassette

1. Pull the EJECT lever to open the cassette compartment lid.
2. Load a cassette with the full reel to the left.

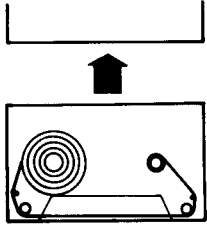

3. Close the lid by pressing it.

#### NOTE:

Be sure to close the lid after loading a cassette. The unit does not operate unless the lid is closed.

### Warning beep tones

The unit emits a warning tone in the following cases;

#### No cassette:

A tone sounds if there is no cassette in the unit when the unit is in the operating mode.

#### End of tape:

A tone sounds when the tape reaches the end in all operating modes.

#### Record/Erase protection:

A tone sounds if you attempt to record/erase a cassette, whose erasure guard tab has been broken.

#### Telephone recording mode:

A tone sounds if you attempt telephone recording when no cord is connected to the TEL REC jack.

#### NOTE:

- Set the hand control switch to STOP before turning the power on. If the switch has been set to DICT, the unit automatically enters the record mode when turning the power on.
- Do not set the hand control switch to DICT during playback, or the unit enters the record mode.
- Do not press the TEL REC button unless you perform telephone recording.

## DICTATION/CONFERENCE RECORDING

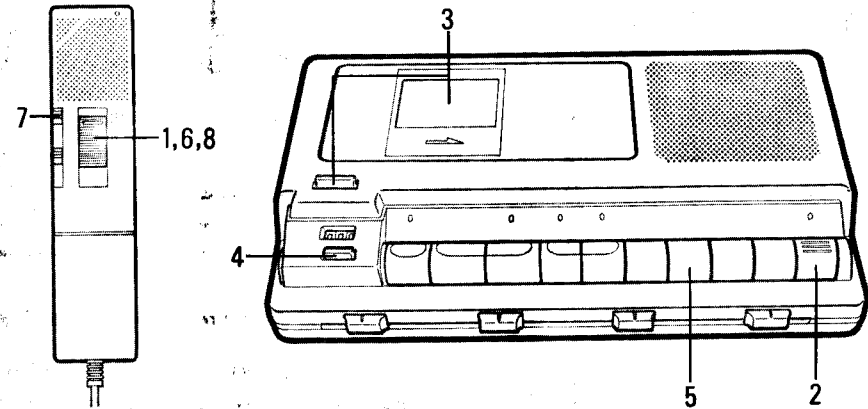

1. Set the hand control switch to STOP.
2. Press the POWER button.
3. Load a cassette.
4. Press the RESET button to set the counter to "000".
  - The tape counter helps you to quickly locate recorded selection for playback.
5. Set the DICT/CONF button to DICT or CONF.
  - DICT: For dictation recording
    - Hold the hand control in a comfortable position approximately 5 - 6 inches away from your mouth.
  - CONF: For conference recording
    - Place the unit in the center of the group.
6. Set the hand control switch to DICT. Recording starts.
  - You need not adjust the VOLUME control while recording. The ALC (Automatic Level Control) circuit in the unit will keep the level at its optimum.
7. Press the INDEX button on the hand control to mark important segments of recording. The unit records a beep tone on the tape.
  - When index searching, the tape stops briefly at each index signal so that you can easily locate important recordings.
8. To pause while recording, set the hand control switch to STOP. To record again, set the switch to DICT.

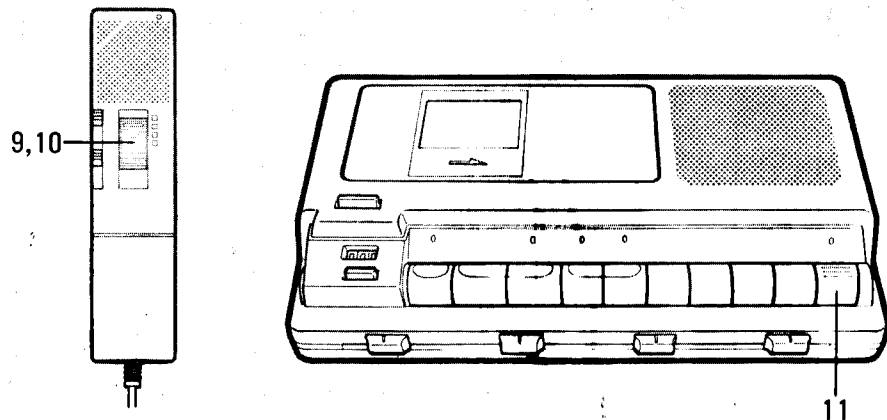

9. To make corrections or to edit, backspace the tape by setting the hand control switch to BACK. Hold the switch until you reach the portion of the recording just before the correction point. Release the switch and the switch returns to the PLAY position automatically. Listen to your recording. At the exact point where the correction is to begin, set the hand control switch to DICT and proceed with your dictation.
10. To end recording, set the hand control switch to STOP.
11. To turn the unit off, press the POWER button again to release.

### Reviewing

1. Set the hand control switch to BACK. Hold the switch until the desired amount of backspace is accomplished.
2. Release the switch; the unit begins to play back your recording.
  - For fast forwarding the tape, press the FFWD button on the hand control.
3. Adjust the VOLUME and TONE controls as desired.
4. You can listen to the playback signal through either the speaker in the unit or the hand control. To activate the hand control speaker, press the MIC/SPKR button to MIC. Leave the button up to listen through the speaker in the unit.
5. To stop reviewing, set the hand control switch to STOP.

## TELEPHONE RECORDING

1. Press the POWER button.
2. Load a cassette.
3. Press the TEL REC button.
4. To stop recording, press the TEL REC button again to release.

### NOTE:

Anytime you press the TEL REC button while the cord is connected to the TEL REC jack, the unit automatically enters the record mode.

- To record a telephone conversation, an optional SRD-50 adaptor must be used.

## TRANSCRIPTION

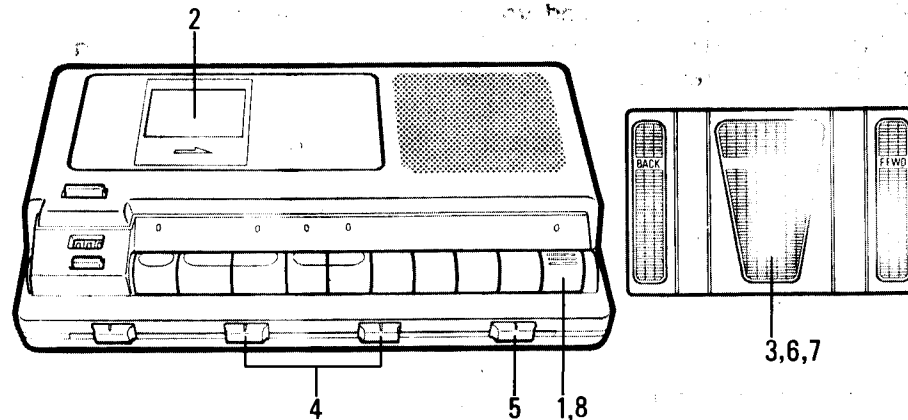

1. Press the POWER button.
2. Load a cassette to be played.
3. Press the PLAY switch on the foot control to begin transcribing. Playback will continue while the switch is being pressed.
  - Playback can also be started by pressing the PLAY button on the unit. In this case, the STOP button can be pressed to stop playback.
4. Adjust the VOLUME and TONE controls as desired.
5. Use the SPEED CONTROL to adjust the playback speed to your liking.
  - The "0" position on the scale is for normal tape speed.
  - The SPEED CONTROL has no effect during recording.
6. If you wish to review your dictation, release the PLAY switch. The tape automatically backspaces according to the BACKSPACE control setting.
  - Use the BACKSPACE control to adjust the automatic backspace feature for your convenience.

- For a longer review, press the BACK switch and the tape backspaces continuously until you release the BACK switch.
  - For fast forwarding the tape, press the FFWD switch.
7. To pause, release the PLAY switch.  
Continue with this start-stop method until the transcription is completed.
  8. To turn the unit off, press the POWER button to release.

### Index search

1. Press the SEARCH button to ON.
2. Press the REW or FFWD button on the unit.  
The tape stops briefly and a beep tone sounds when the tape reaches the index mark you have recorded.
  - When using the foot control, press the BACK or FFWD switch.
  - When using the hand control, set the hand control switch to BACK or press the FFWD button.

### Erasing

After transcription is completed, you can erase the cassette.

1. Press and hold down the ERASE button, then press the REW button.
2. When the tape reaches the end, a beep tone sounds. Press the STOP button to stop erasing.
  - You can also perform "forward erasing" by pressing both ERASE and FFWD buttons.

### Use as a tape player

You can also play a pre-recorded cassette on the unit. Load a cassette and press the PLAY button. Use the FFWD or REW button to advance or rewind the tape rapidly.

### Safeguards against accidental erasure

- To protect side A, break out tab (1). To protect side B, break out tab (2).
- To record or erase a protected cassette, cover the erase guard tab openings with adhesive tape (3).

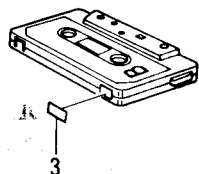
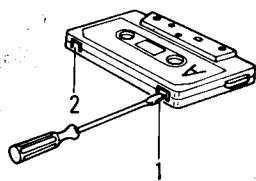

## MAINTENANCE

### Cleaning the cabinet

Use a clean soft cloth moistened with plain lukewarm water and wrung dry. Never use benzol, benzene or other strong chemical cleaners since these could damage the finish of your unit. It is important that no liquid reaches the inside of the unit.

### Cleaning the heads

For continued high performance, periodically clean the heads, pinch roller and capstan whenever an accumulation of dust and red-brown oxide particles is noticed.

To do this, pull the EJECT lever to open the cassette compartment lid. Remove the cassette and switch off the power. Carefully rub each head (4, 5), pinch roller (3) and capstan (2) with a cotton swab (1) moistened with isopropyl alcohol or special head-cleaning fluid.

